

**NEPTUNE** BX3 Plus  
SS9473SCM

# 1 PRODUCT

## 1.1 TECHNICAL SPECIFICATIONS

Type	SS9473SCM
LED colors	500W Laser source
Angle	0.6°-30°
Power	750W
Control Protocol	DMX512, RDM, sACN, ARTNET, NFC, CRMX(Optional)
Voltage Range	100-240V~,50/60Hz
Input Current	110V/7A,220V/3.5A
Protection	IP66
Operation Temperature	-20°C~45°C
Dimensions	435x294x716mm
Weight	35kg

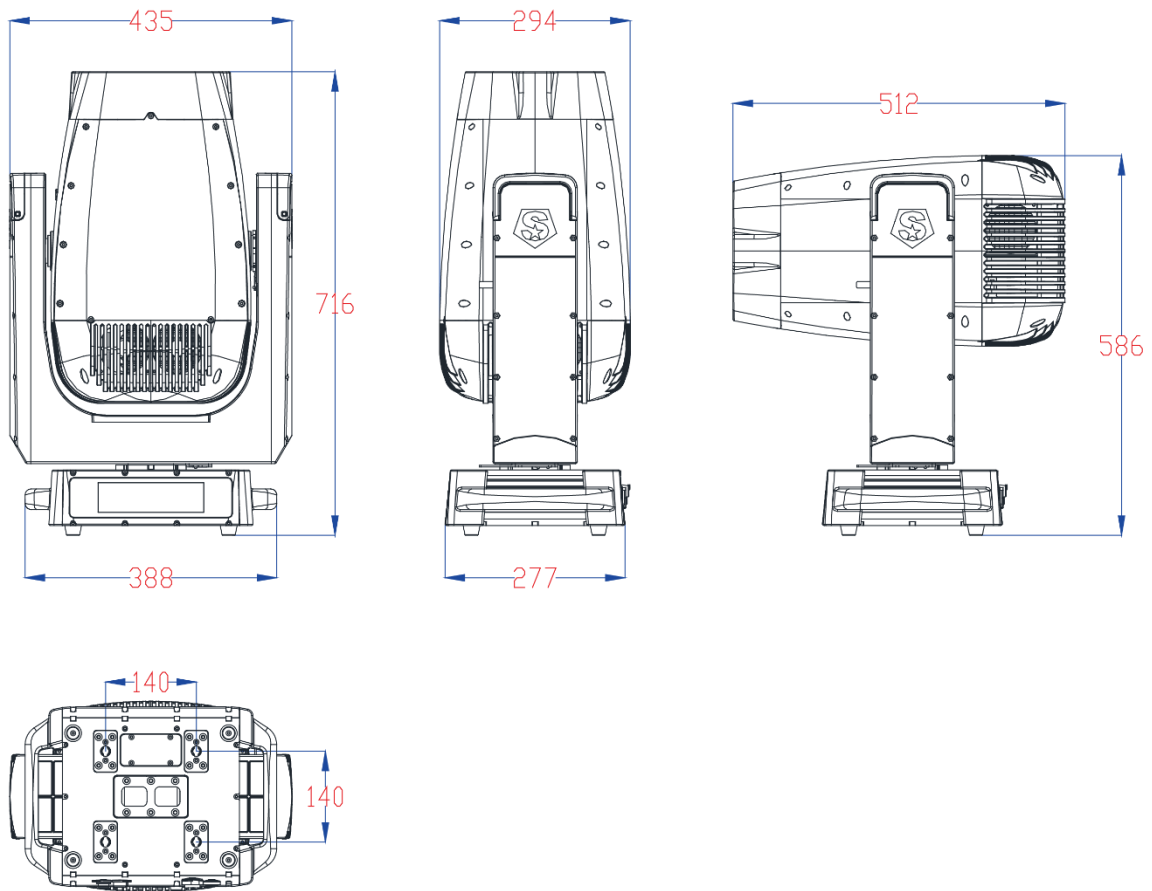

## 1.2 Safety Notes

### **IMPORTANT**

- This product must be installed by a qualified professional.
- In order to maintain this condition and to ensure a safe operation, it is absolutely necessary for the user to follow the safety instructions and warning notes
- The manufacturer will not accept liability for any resulting damages caused by the non-observance of this manual or any unauthorized modification to the device.

### **CAUTION!**

- Make sure that the available voltage is not higher than stated on the rear panel.
- Do not touch the power cables if your hands are wet.
- The earth wire must always be connected to the ground. Therefore it is essential to connect the yellow/green conductor to earth.
- Make sure that the power-cord is never crimped or damaged by sharp edges. Check the device and the power-cord from time to time. The electric connection, repairs and servicing must be carried out by a qualified employee.
- Always disconnect power input cable to completely remove power from unit when not in use or before cleaning or servicing the fixture.
- Do not switch the fixture on and off in short intervals as this would reduce the lamp's life.
- Do not touch the device's housing bare hands during its operation (housing becomes hot)! The surface of the product's casing can reach up to 70° C (158° F) during operation. Avoid contact by persons and materials. Do not install the product in a location where there is a risk of accidental contact. Allow the product to cool for at least 10 minutes before handling.
- For replacement use lamps and fuses of same type and rating only.
- Please protect the fixture and avoid destroy during transport and installation. If there is any damage to the coating, the shell may be corroded.
- When hanging lamps and lanterns, it is necessary to verify that facilities and hooks can bear at least 10 times the weight of lamps and lanterns.
- Fix the safety rope at the correct holes only. Only operate the fixture after having checked that the housing is firmly closed and all screws are tightly fastened.
- The ambient temperature of this device is -20°C -45°C, please use the lighting fixtures within this range. (Note: When the laser light source detects a temperature between -20°C and 0°C, the device needs to heat the internal temperature to above 0°C before it lights up.)
- During the initial start-up some smoke or smell may arise. This is a normal process and does not necessarily mean that the device is defective.

### **Electrical Warning**

- The light source contained in this luminaire shall only be replaced by the manufacturer or his service agent or a similar qualified person
- For replacement use lamps and fuses of same type and rating only.
- The lens has to be replaced when it is obviously damaged, so that its function is impaired, e. g. due to cracks or deep scratches!

### **Keep the product well away from flammable materials**

- Keep all combustible materials (e.g. fabric, wood, paper) at least 1000 mm (40 in.) away from the product.

- Ensure that there is free and unobstructed airflow around the product. Provide a minimum clearance of 150 mm (6 in.) around fans and air vents.
- Do not illuminate surfaces within 3 m (10 ft.) of the product.
- Do not install a fuse that has a higher rating than the one originally installed in the product. Do not bypass fuses.
- Do not stick filters, masks or other materials onto optical components.
- If the fixture seems to be abnormally hot, shows signs of melting or emits smoke, disconnect the fixture from power immediately and allow it to cool. Do not touch the fixture without heatproof safety gloves. Keep the fixture well away from combustible and flammable materials.

**NEVER LOOK DIRECTLY INTO THE LIGHT SOURCE!  
RETINA INJURY RISK - MAY INDUCE BLINDNESS!**

**Do not point the front of the fixture towards the sun or other strong light sources. The front lens focuses and concentrates light just like a magnifying glass. Strong light can cause internal damage to the fixture, melting components or starting an internal fire within seconds.**

**To avoid problems from strong light sources:**

- Do not expose the front of a fixture to sunlight or any other strong light source. Avoid pointing other high-powered beam lights directly at the fixture.
- Do not focus a light beam from one lighting fixture directly towards another.
- For outdoor applications during daylight, make sure that the front face of any fixture is shielded or points away from the sun, even when not in use.
- Do not expose the product to heat (from other lighting fixtures for example).

# 2 INSTALLATION

## 2.1 MOUNTING

### Truss installation

- ◆ Keep all combustible materials (e.g. fabric, wood, paper) at least 500 mm (20 in.) away from the product.
- ◆ For overhead use, always install a safety cable that can hold at least 10 times the weight of the fixture.
- ◆ For overhead installation, the fixture must be always secured with a safety wire that can bear at least 10 times the weight of the fixture;
- ◆ Secure the fixture with a safety cable through the rear safety eye and truss as shown..
- ◆ Ensure that the structure (truss) to which you are attaching the fixture is secure

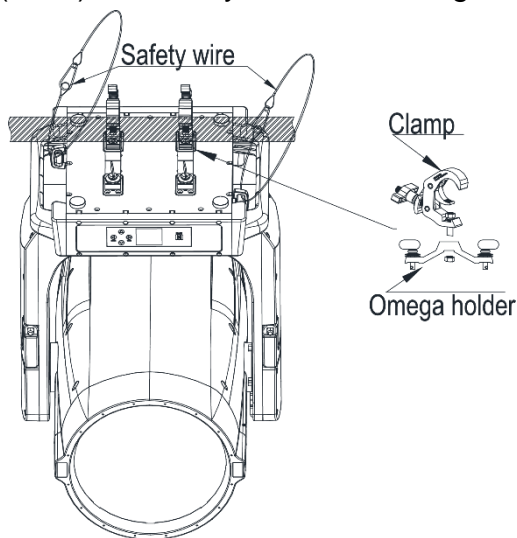

## 2.2 Fuse replacement

- ◆ Remove the safety cap by a screwdriver.
- ◆ Fetch the old fuse from safety cap.
- ◆ Install a new fuse.
- ◆ Install the safety cap.

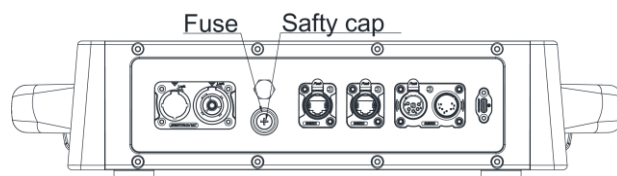

## 2.3 POWER CONNECTIONS

- ◆ POWER Linking: 1 units@110V; 2 units@220V.
- ◆ This product has an auto-ranging power supply that can work with an input voltage range of 100–240 VAC, 50/60 Hz.

### AC Plug

Connection	Wire (U.S.)	Wire(Europe)	Screw Color
AC Live	Black	Brown	Yellow/Brass
AC Neutral	White	Blue	Silver
AC Ground	Green/Yellow	Green/Yellow	Green

## 2.4 Data network requirements

- ◆ Connect the DMX512 controller to the units in series. A DMX 512 data link is required in order to control the fixture via DMX. The fixture has 3/5-pin XLR connectors for DMX data input and output.
- ◆ Each unit has N DMX channels so the DMX Addresses should increase by increments of 1, (Nx1)+1, (Nx2)+1, (Nx3)+1...
- ◆ Any DMX address in the range from 001 to 512 may be used.
- ◆ Connect the DMX-output of the first fixture in the DMX chain with the DMX-input of the next fixture. Always connect one output with the input of the next fixture until all fixtures are connected.
- ◆ Caution: At the last fixture, the DMX-cable has to be terminated with a terminator. Solder a 120 Ω resistor between Signal (-) and Signal (+) into a 3/5-pin XLR-plug and plug it in the DMX-output of the last fixture.

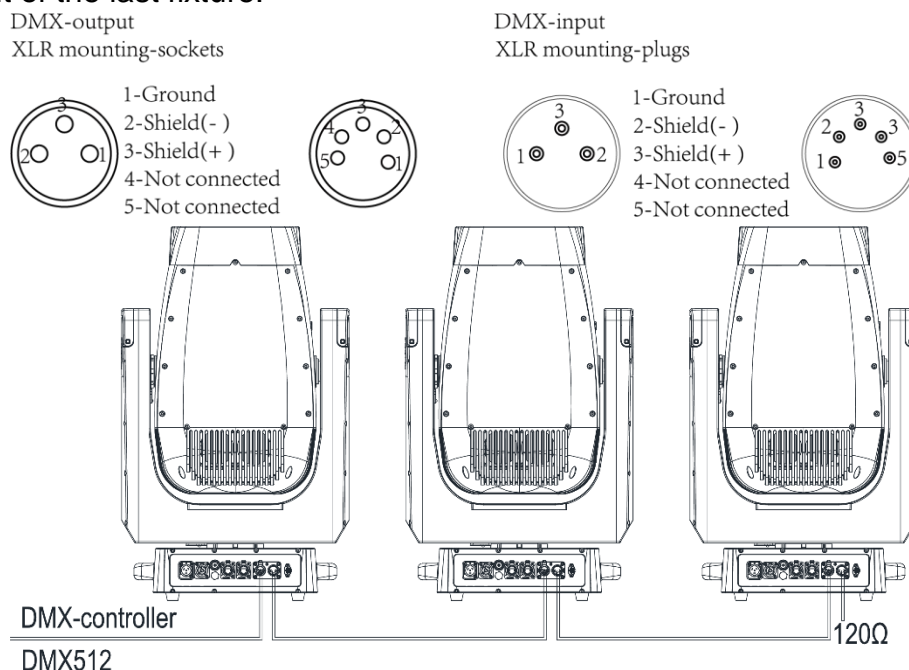

## 2.5 Update software

- ◆ Steps of updating software with USB-C interface:
  1. Insert USB-C U dish into USB-C interface
  2. After finding "Upgrade Software" in the menu, Find the corresponding software and click OK

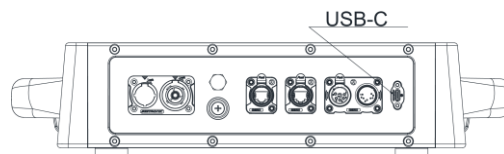

# 3 FUNCTIONS AND SETTINGS

## 3.1 DISPLAY OPERATION

- ◆ MENU: Used to access the menu or to return a previous menu option;
- ◆ ENTER: Used to select and store the current menu or confirm the current function value or option within a menu;
- ◆ UP: Navigates downwards through the menu list and increases the numeric value when in a function;
- ◆ DOWN: Navigates upwards through the menu list and decreases the numeric value when in a function;
- ◆ Lock screen password: Long press 5s Left, Input after the screen is bright - UP/DOWN/UP/DOWN

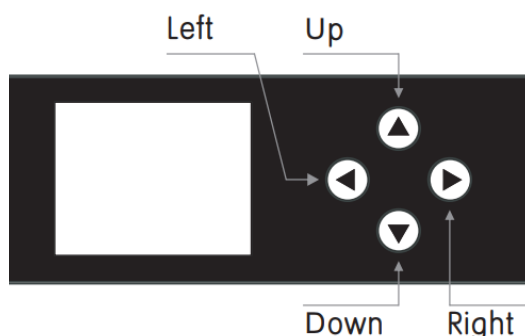

## 3.2 Menu Map

ADDRESS	001 – 512(Default 001)		DMX address setting	
PERSON	BASIC		Use the menu to select desired channel mode	
	STANDARD (Default)			
	EXTEND			
RUNMODE	DMX512 (Default)		Select Signal	
	ARTNET		Default: DMX512	
	ARTNET TO DMX		CUSTOM1-2 Set up get into EDIT	
	Sacn		MENU edit	
	AUTO			
	CUSTOM1			
	CUSTOM2			
OPTION	PAN INVERT	OFF (Default)	PAN moving direction selection	
		ON		
	TILT INVERT	OFF (Default)	TILT moving direction selection	
		ON		
	PAN DEGREE	630	PAN moving degree selection	
		540 (Default)		
	BLACKOUT	OFF (Default)	Select OFF blackout without delay	
		ON	Select ON Blackout delay 3s	
	PERFORM	STUDIO		Fan mode low speed

	POWER		Fast rotation of fan, all power
	LIVE (Default)		Automatic rotation of fan
SUN PROTECTION	ON(Default)		Turn the fixtures Head to earth
	OFF		
DIMMER SPEED	Halogen (Default)		Dimming speed LED (fast) to Halogen (slow);
	LED		
DIMMER CURVE	LINEAR		Sets the Dimmer curve
	SQUARE LAW (Default)		
	INV. SQUARE LAW		
	S-CURVE		
LED PWM	1200Hz (Default)		Sets the PWM frequency
	2400Hz		
	4000Hz		
	6000Hz		
	25000Hz		
NO DMX MODE	FREEZE(Default)		Hold after loss of DMX signal
	BLACKOUT		Blackout after loss of DMX signal
DISPLAY TIME	On		Display backlight always on
	30s		Turns off display backlight after 30s/1min
	1min (Default)		
	2min		/2min of inactivity
DISPLAY LOCK	OFF		Locks display (passcode is <UP>, <DOWN>,<UP>, <DOWN>, <ENTER>)
	ON (Default)		
LOAD PARA	OFF		Upload data
	NO		Not upload data
SETTING	RECOVERY	****	Restore default factory settings.
	CLEAN EDIT1	****	Clean customer self-editing scene 1
	CLEAN EDIT2	****	Clean customer self-editing scene 2
	WDMX HIDE	YES	
NO			
NETWORK	NET SWITCH	2.xxx.xxx.xxx	Net switch off IP mode
		10.xxx.xxx.xxx	Net switch on IP mode
	UNIVERS	0-255	Packet group Settings
	IP MODE	DEFAULT IP	Default IP
		CUSTOM IP	Customer's IP
CUSTOM IP	XX.XX.XX.XX	Customer's IP setting	
PT ENCODER	OFF		XY Encoder switch.
	ON		OFF is close; ON is open.
WDMX RESET	YES		Clear the receiver's message
	NO		Do not clear the receiver's message

	LANGUAGE	****	Chinese	Language selection	
			ENGLISH(Default)		
	SIGNAL	ONLY XLRDMX (Default)		ONLY XLR is wire only	
		XLRDMX FIRST		XLR FIRST is wire first	
		ONLY WDMX		ONLY WDMX is wireless only	
WDMX FIRST		WDMX FIRS is wireless first			
WDMX TO XLRDMX		WDMX TO DMX is wireless to wired			
EDIT	EDIT 1-2	STEP 1-30	PAN	0-255	Edit the custom programs1-30 Select play 【EDIT 1】 in RUNMOEDE CUSTOM 1; Select play 【EDIT 2】 in RUNMOEDE CUSTOM 2
			TILT	0-255	
			PT SPEED	0-255	
			PAN ROTA	0-255	
			CMY C	0-255	
			CMY M	0-255	
			CMY Y	0-255	
			CTO	0-255	
			COLOR	0-255	
			ROTA.GOBO	0-255	
			GOBO.ROTA	0-255	
			FIXED GOBO	0-255	
			ANIMATION.D	0-255	
			ANIMATION.R	0-255	
			P/F 1 INDEX	0-255	
			P/F 1.ROTA	0-255	
			P/F 2 INDEX	0-255	
			P/F 2.ROTA	0-255	
			ZOOM	0-255	
			FOCUS	0-255	
DIMMER	0-255				
STROBE	0-25				
TIME	0-255				
USE	YES/NO	Select YES to run the steps user need.			
MANUAL	Auto Test			Auto Test channel	
	CHANNEL	PAN	0-255	Manual control channel	
		TILT	0-255		
		PT SPEED	0-255		
		PAN ROTA	0-255		
		CMY C	0-255		
		CMY M	0-255		
		CMY Y	0-255		
		CTO	0-255		

		COLOR	0-255		
		ROTA.GOBO	0-255		
		GOBO.ROTA	0-255		
		FIXED GOBO	0-255		
		ANIMATION.D	0-255		
		ANIMATION.R	0-255		
		P/F 1 INDEX	0-255		
		P/F 1.ROTA	0-255		
		P/F 2 INDEX	0-255		
		P/F 2.ROTA	0-255		
		ZOOM	0-255		
		FOCUS	0-255		
		DIMMER	0-255		
		STROBE	0-25		
	DEBUG HIDE	YES		Factory testing mode. All stepper motors are not controlled by signal, It only works again after the reset.	
		NO			
	RESET	ALL RESET		Select Yes/No to carry out all reset	
		PT RESET		Select Yes/No to carry out P/T reset	
		COLOR GOBO SYS		Color/CMYK reset	
		ZOOM FOCUS RESET		Focus/Zoom reset	
INFO	FIXTURE HOURS			Hours of fixture use	
	LED USE HOURS			LED use time	
	TEMPERATURE			LED temperature	
	VERSION			Software versions	
	NETWORK			network address	
	RDM	UID	0x388Axxxxxxx		Check fixture's ID
		LABEL			Check fixture's LABEL
	SYSTEM ERROR	MEMORY IC			Memory IC
		ANGLESENSOR			Angle Sensor
		LED TEMPERATURE 1			
		LED TEMPERATURE 2			
		PAN SENSOR			Pan Sensor
		PAN ENCODER			Pan Encoder
		PAN DRIVEIC			Pan Drive IC
		TILT SENSOR			Tilt Sensor
		TILT ENCODER			Tilt Encoder
		TILT DRIVEIC			Tilt Drive IC
TEMPERATURE			Temperature		
CMY_C RESET			CMY C Reset		
CMY_M RESET			CMY M Reset		

		CMY_Y RESET		CMY Y Reset
		CTO RESET		CTO Reset
		COLOR RESET		Color Reset
		GOBO RESET		Gobo Reset
		RGOBO RESET		Rotate Gobo Reset
		FGOBO RESET		Fixed Reset
		ANIMATION RESET		Animation Reset
		P/F 1 RESET		P/F 1 Reset
		P/F 2 IRESET		P/F 2 Reset
		ZOOM RESET		Zoom Reset
		FOCUS RESET		Focus Reset
SERVICE	****	PAN	±127	Pan position fine adjustment
		TILT	±127	Tilt position fine adjustment
		CMY-C	±127	CMY-C position fine adjustment
		CMY-M	±127	CMY-M position fine adjustment
		CMY-Y	±127	CMY-Y position fine adjustment
		CTO	±127	CTO position fine adjustment
		COLOR	±127	Colour position fine adjustment
		ROTA. GOBO	±127	Rotate Gobo position fine adjustment
		GOBO.ROTA	±127	Self-rotation position fine adjustment
		FIXED GOBO	±127	Fixed Gobo position fine adjustment
		ANIMATION	±127	Animation Gobo position fine adjustment
		P/F 1 INDEX	±127	P/F 1 position fine adjustment
		P/F 1 ROTA	±127	Prism 1 position fine adjustment
		P/F 2 INDEX	±127	P/F 2 position fine adjustment
		P/F 2 ROTA	±127	Prism 2 position fine adjustment
		ZOOM	±127	Zoom position fine adjustment
		FOCUS	±127	Focus position fine adjustment
UPDATE SOFTWARE				Update software
All passwords of this product are <UP>, <DOWN>,<UP>, <DOWN>, <ENTER>				

# 4 USING A DMX512 CONTROLLER

## 4.1 DMX CONTROL

BASIC (26CH)	STANDARD (33CH)	EXTEND (38CH)	VALUE	Functions
1	1	1	000-255	PAN
-	2	2	000-255	PAN FINE
2	3	3	000-255	TILT
-	4	4	000-255	TILT FINE
3	5	5	000-255	PT Speed
4	6	6	<b>PAN Motor continuous rotation</b>	
			0-63	stop rotation by spinout
			64-127	stop rotation by shortcut
			128-189	Forwards Pan rotation from fast to slow
			190-193	No rotation
			194-255	Backwards Pan rotation from slow to fast
5	7	7	000-255	CYAN
		8	000-255	CYAN FINE
6	8	9	000-255	MAGENTA
		10	000-255	MAGENTA FINE
7	9	11	000-255	YELLOW
		12	000-255	YELLOW FINE
8	10	13	000-255	CTO
		14	000-255	CTO FINE
9	11	15	<b>COLOUR MACRO</b>	
			000-019	No Function
			020-021	3000K
			022-023	3200K
			024-025	3500K
			026-027	4000K
			028-029	4500K
			030-031	5000K
			032-033	5400K
			034-035	5600K
			036-037	6000K
			038-039	6500K
			040-041	7000K
			042-043	L106
			044-045	L194
			046-047	L019
			048-049	R08
050-051	L213			
052-053	R80			
054-055	L202			
056-057	L328			
058-059	R3314			

			060-061	L101
			062-063	L768
			064-255	MACRO EFFECT R->G->B->R
10	12	16	000-255	CMY SPEED(SPEED 100%->1)
11	13	17	<b>COLOR WHEEL 19+1</b>	
			000-007	WHITE
			008-010	COLOR 1
			011-013	COLOR 2
			014-016	COLOR 3
			017-019	COLOR 4
			020-022	COLOR 5
			023-025	COLOR 6
			026-028	COLOR 7
			029-031	COLOR 8
			032-034	COLOR 9
			035-037	COLOR 10
			038-040	COLOR 11
			041-043	COLOR 12
			044-046	COLOR 13
			047-049	COLOR 14
			050-052	COLOR 15
			053-055	COLOR 16
			056-058	COLOR 17
			059-061	COLOR 18
062-064	COLOR 19			
065-191	COLOR WHELL1 0-360°			
192-222	COLOR WHELL1 RAINBOW EFFECT(SPEED 100%->1)			
2223-224	STOP			
225-255	COLOR WHELL1 RAINBOW EFFECT(SPEED 1->100%)			
-	-	18	000-255	COLOR WHEEL FINE
12	14	19	<b>ROTATING GOBO 12+1</b>	
			000-010	ROTATING WHITE
			011-014	ROTATING GOBO 1
			015-018	ROTATING GOBO 2
			019-022	ROTATING GOBO 3
			023-026	ROTATING GOBO 4
			027-030	ROTATING GOBO 5
			031-034	ROTATING GOBO 6
			035-038	ROTATING GOBO 7
			039-042	ROTATING GOBO 8
			043-046	ROTATING GOBO 9
			047-050	ROTATING GOBO 10
			051-054	ROTATING GOBO 11
			055-058	ROTATING GOBO 12
059-063	ROTATING GOBO 1 SHAKE (SPEED 1 —> 100%)			

			064-068	ROTATING GOBO 2 SHAKE (SPEED 1 → 100%)
			069-073	ROTATING GOBO 3 SHAKE (SPEED 1 → 100%)
			074-078	ROTATING GOBO 4 SHAKE (SPEED 1 → 100%)
			079-083	ROTATING GOBO 5 SHAKE (SPEED 1 → 100%)
			084-088	ROTATING GOBO 6 SHAKE (SPEED 1 → 100%)
			089-093	ROTATING GOBO 7 SHAKE (SPEED 1 → 100%)
			094-098	ROTATING GOBO 8 SHAKE (SPEED 1 → 101%)
			099-103	ROTATING GOBO 9 SHAKE (SPEED 1 → 101%)
			104-108	ROTATING GOBO 10 SHAKE (SPEED 1 → 102%)
			109-113	ROTATING GOBO 11 SHAKE (SPEED 1 → 102%)
			114-118	ROTATING GOBO 12 SHAKE (SPEED 1 → 103%)
			119-127	WHITE
			128-190	STATIC GOBO POSITIVE WATER EFFECT (SPEED 100 → 1%)
			191-192	STOP WATER EFFECT
			193-255	STATIC GOBO REVERSE WATER EFFECT (SPEED 1 → 100%)
			<b>GOBO ROTATING</b>	
			000-120	ROTATING GOBO ANGLE ADJUSTMENT (0 → 360°)
			121-125	STOP
			126-165	ROTATING GOBO SHAKE (SPEED 1 → 100%)
			166-170	STOP
			171-210	ROTATING GOBO POSITIVE ROTATION (SPEED 100% → 1)
			211-215	STOP
			216-255	ROTATING GOBO REVERSE ROTATION (SPEED 1 → 100%)
13	15	20		
-	16	21	000-255	GOBO ROTATING FINE
			<b>FIXED GOBO WHEEL 19+1</b>	
			0-10	WHITE
			11-13	FIXED GOBO 1
			14-16	FIXED GOBO 2
			17-19	FIXED GOBO 3
			20-22	FIXED GOBO 4
			23-25	FIXED GOBO 5
			26-28	FIXED GOBO 6
			29-31	FIXED GOBO 7
			32-34	FIXED GOBO 8
			35-37	FIXED GOBO 9
			38-40	FIXED GOBO 10
			41-43	FIXED GOBO 11
			44-46	FIXED GOBO 12
			47-49	FIXED GOBO 13
			50-52	FIXED GOBO 14
			53-55	FIXED GOBO 15
			56-58	FIXED GOBO 16
14	17	22		

			59-61	FIXED GOBO 17
			62-64	FIXED GOBO 18
			65-67	FIXED GOBO 19
			68-70	FIXED GOBO 1 SHAKE (SPEED 1 → 100%)
			71-73	FIXED GOBO 2 SHAKE (SPEED 1 → 100%)
			74-76	FIXED GOBO 3 SHAKE (SPEED 1 → 100%)
			77-79	FIXED GOBO 4 SHAKE (SPEED 1 → 100%)
			80-82	FIXED GOBO 5 SHAKE (SPEED 1 → 100%)
			83-85	FIXED GOBO 6 SHAKE (SPEED 1 → 100%)
			86-88	FIXED GOBO 7 SHAKE (SPEED 1 → 100%)
			89-91	FIXED GOBO 8 SHAKE (SPEED 1 → 100%)
			92-94	FIXED GOBO 9 SHAKE (SPEED 1 → 100%)
			95-97	FIXED GOBO 10 SHAKE (SPEED 1 → 100%)
			98-100	FIXED GOBO 11 SHAKE (SPEED 1 → 100%)
			101-103	FIXED GOBO 12 SHAKE (SPEED 1 → 100%)
			104-106	FIXED GOBO 13 SHAKE (SPEED 1 → 100%)
			107-109	FIXED GOBO 14 SHAKE (SPEED 1 → 100%)
			110-112	FIXED GOBO 15 SHAKE (SPEED 1 → 100%)
			113-115	FIXED GOBO 16 SHAKE (SPEED 1 → 100%)
			116-118	FIXED GOBO 17 SHAKE (SPEED 1 → 100%)
			119-121	FIXED GOBO 18 SHAKE (SPEED 1 → 100%)
			122-124	FIXED GOBO 19 SHAKE (SPEED 1 → 100%)
			125-127	WHITE
			128-190	STATIC GOBO JUMPING WATER EFFECT (SPEED 100 → 1%)
			191-192	STOP WATER EFFECT
			193-255	STATIC GOBO FLOWING WATER EFFECT (SPEED 1 → 100%)
15	18	23	0-255	<b>Insert effect wheel</b>
			<b>ANIMATION DISC ROTATION</b>	
16	19	24	0-10	WHITE
			11-127	Animation Insertion CW Rotate Slow to Fast
			128-138	Rotation STOP
			139-255	Animation Insertion CCW Rotate Fast to Slow
			<b>P/F INDEX 1</b>	
17	20	25	0-10	WHITE
			11-50	PRISM 1
			51-100	PRISM 2
			101-150	PRISM 3
			151-200	PRISM 4
			201-255	FROST 1
			<b>PRISM 1 ROTATION</b>	
18	21	26	000-010	WHITE
			011-145	PRISM INSERT AND ADJUST THE ANGLE (0 → 360°)
			146-150	STOP
			151-200	PRISM INSERT AND POSITIVE ROTATION

				(SPEED 100% → 1)
			201-205	STOP ROTATION
			206-255	PRISM INSERT AND REVERSE ROTATION (SPEED 1 → 100%)
19	22	27	<b>P/F INDEX 1</b>	
			0-10	WHITE
			11-50	PRISM 5
			51-100	PRISM 6
			101-150	PRISM 7
			151-200	PRISM 8
			201-255	FROST 2
20	23	28	<b>PRISM 2 ROTATION</b>	
			000-010	WHITE
			011-145	PRISM INSERT AND ADJUST THE ANGLE (0 → 360°)
			146-150	STOP
			151-200	PRISM INSERT AND POSITIVE ROTATION (SPEED 100% → 1)
			201-205	STOP ROTATION
			206-255	PRISM INSERT AND REVERSE ROTATION (SPEED 1 → 100%)
21	24	29	000-255	<b>ZOOM</b>
	25	30	000-255	ZOOM FINE
22	26	31	000-255	<b>FOCUS</b>
	27	32	000-255	FOCUS FINE
23	28	33	<b>AUTO FOCUS</b>	
			000-012	NO FUNCTION
			013-039	5 METER
			040-066	7 METER
			067-093	9 METER
			094-120	11 METER
			121-147	13 METER
			148-174	15 METER
			175-201	17 METER
			202-228	19 METER
			229-255	21 METER
	29	34	000-255	AUTO FOCUS FINE
24	30	35	000-255	DIMMER
	31	36	000-255	DIMMER FINE
22	32	37	<b>STROBE</b>	
			000-009	NO FUNCTION
			010-099	STROBE ( FROM SLOW TO FAST )
			100-109	NO FUNCTION
			110-179	LIGHTNING STROBE
			180-189	NO FUNCTION
			190-255	RANDOM STROBE
23	33	38	<b>CONTROL CHANNEL</b>	

			0-10	NO FUNCTION
			11-15	PAN/TILT BLACK ACTIVATED
			16-20	PAN/TILT BLACK DEACTIVATED
			21-25	PAN INVERT
			26-30	TILT INVERT
			31-35	PAN/TILT INVERT OFF
			36-40	PAN DEGREE 630
			41-45	PAN DEGREE 540
			46-50	Sun Protection On
			51-55	Sun Protection Off
			56-100	RESERVED
			101-105	STUDIO
			106-110	POWER
			111-115	LIVE
			116-130	RESERVED
			131-135	DIMMER SPEED Halogen
			136-140	DIMMER SPEED LED
			141-145	DIMMER CURVE LINEAR
			146-150	DIMMER CURVE SQUARE LAW
			151-155	DIMMER CURVE INV. SQUARE LAW
			156-160	DIMMER CURVE S-CURVE
			161-165	1200Hz
			166-170	2400Hz
			171-175	4000Hz
			176-180	6000Hz
			181-185	25000Hz
			186-200	RESERVED
			201-205	ALL RESET
			206-210	XY RESET
			211-215	COLOR\GOBO RESET
			216-220	ZOOM\FOCUS RESET
			221-255	NO FUNCTION